

SC16 2016



Contenitore

Materiali

STRUTTURA CONTENITORE: pannelli di listellare impiallacciati in Fossil oak o rovere affumicato, finiti con vernice trasparente a base acqua o a base solvente. Bordo a 45° in legno massello di Fossil oak o rovere affumicato.

CASSETTI: listellare impiallacciato in Fossil oak o rovere affumicato, finiti con vernice trasparente a base acqua o a base solvente, montati su guide con meccanismo di ammortizzazione.

FRONTALI CASSETTI: listellare impiallacciato in Fossil oak o rovere affumicato, finiti con vernice trasparente a base acqua o a base solvente. Oppure in lamiera in ottone striato, acciaio striato grigio o acciaio délabré scuro. Bordo a 45° e maniglia in massello di essenza.

PIANO: listellare impiallacciato con Fossil oak o rovere affumicato, finiti con vernice trasparente a base acqua o a base solvente. Oppure pannello interno in alluminio strutturale rivestito con lamiera in ottone striato, acciaio striato grigio o acciaio délabré scuro. Oppure marmo Grey Stone, bianco Carrara, Calacatta Oro, Emperador Dark, Grigio Carnico finito a mano e trattato con prodotti idrorepellenti o finito con poliestere opaco. Oppure composito MDI.

BASAMENTO: acciaio verniciato a polvere nero opaco e piede in acciaio brunito. Sottopiede regolabile in termoplastica.

PIEDINI: acciaio brunito. Sottopiede regolabile in termoplastica.

+info:
<http://www.depadova.com/materials.pdf>

Esempi di composizione

M75

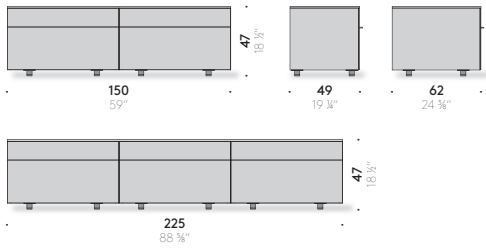

M75

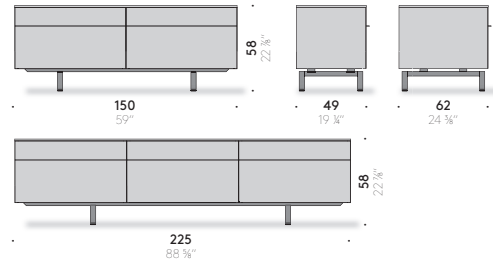

M90

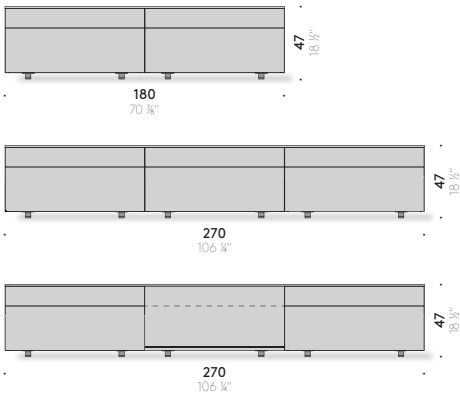

M90

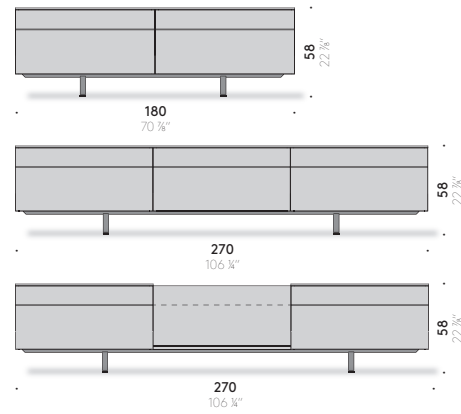

M120

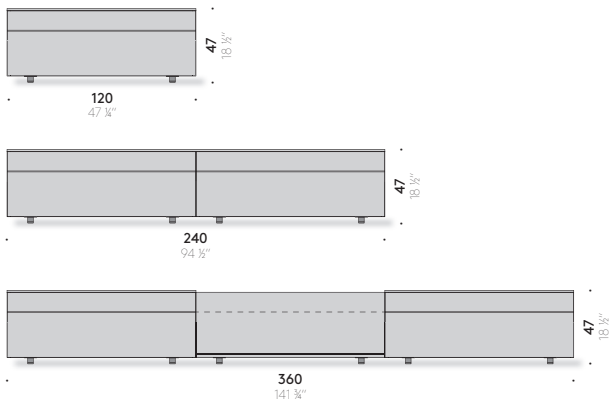

M120

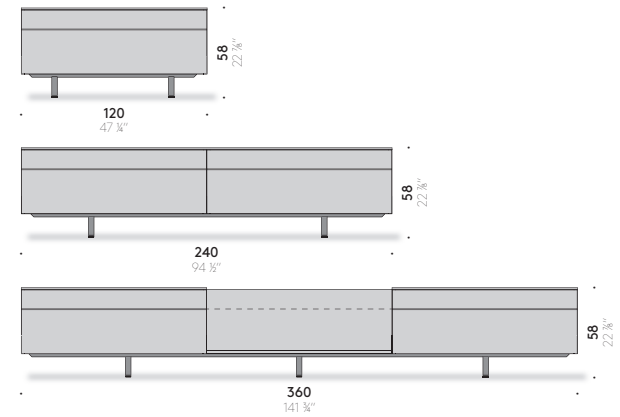

SC16 2016



Cabinet

Materials

CARCASS: blockboard panels veneered in Fossil oak or smoked oak, finished with transparent water-based or solvent-based coating. 45° edges in solid wood (Fossil oak or smoked oak).

DRAWERS: blockboard, veneered in Fossil oak or smoked oak, finished with transparent water-based or solvent-based coating. Installed on runners with soft-close system.

DRAWER FRONT PANELS: blockboard, veneered in Fossil oak or smoked oak, finished with transparent water-based or solvent-based coating. Or in sheet in striped DeLabré G7 brass, striped DeLabré 7022 F12 stainless steel or DeLabré B E5 stainless steel. 45° edge and handle in solid wood.

TOP: blockboard, veneered in Fossil oak or smoked oak, finished with transparent water-based or solvent-based coating. Or interior panel in structural aluminium covered by sheet in striped DeLabré G7 brass, striped DeLabré 7022 F12 stainless steel or DeLabré B E5 stainless steel. Or in Grey Stone, white Carrara marble, Calacatta Oro, Emperador Dark or grey Carnico - treated with water repellent products or finished with matt polyester. Or in MDI composite.

BASE: matt black powder-coated steel and feet in burnished steel. Adjustable thermoplastic glide foot.

FEET: burnished steel. Adjustable thermoplastic glide foot.

+info:
<http://www.depadova.com/materials.pdf>

Composition Examples

M75

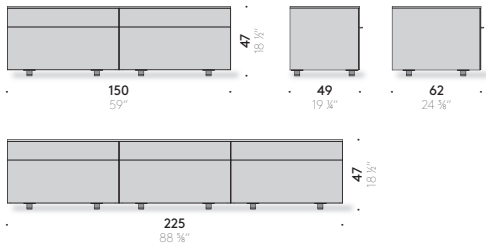

M75

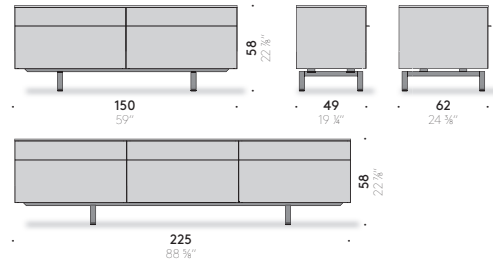

M90

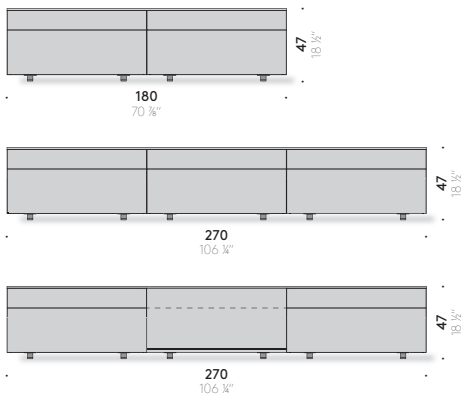

M90

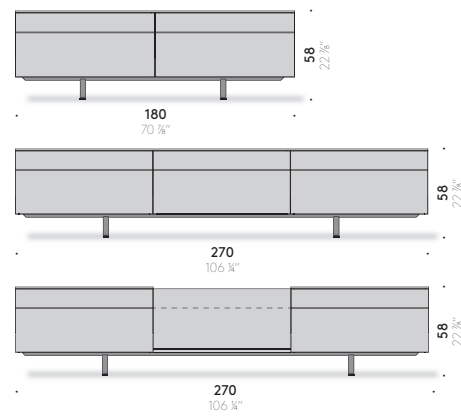

M120

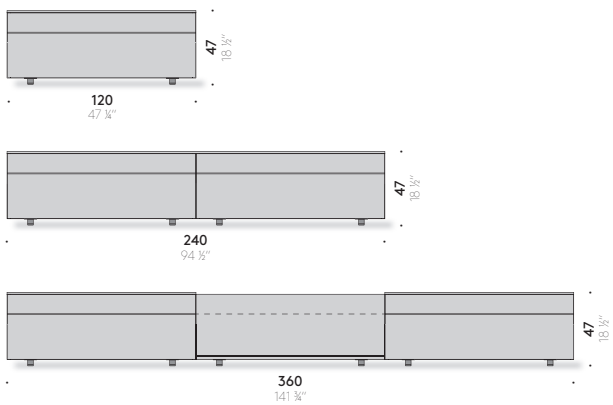

M120

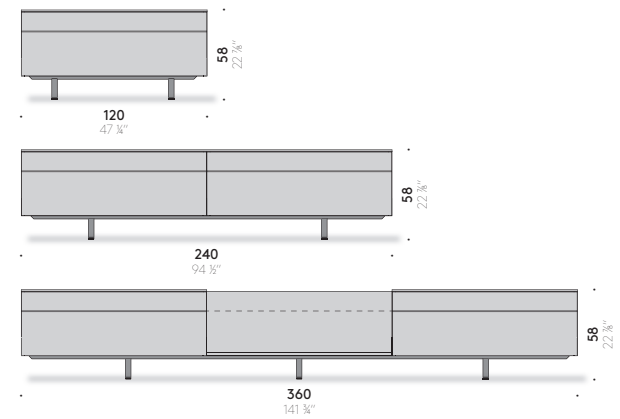

SC16 2016



Élément de rangement

Matériaux

STRUCTURE ÉLÉMENT DE RANGEMENT: panneaux de latté plaqués en Fossil oak ou chêne fumé, finis avec peinture transparente à l'eau ou à base de solvant. Bord à 45° en bois massif de Fossil oak ou chêne fumé.

TIROIRS: latté plaqué en Fossil oak ou chêne fumé, finis avec peinture transparente à l'eau ou à base de solvant, montés sur glissières avec mécanisme d'amortissement.

FAÇADES TIROIRS: panneau de latté plaqué en Fossil oak ou en chêne fumé, fini avec peinture transparente à l'eau ou à base de solvant. Ou panneau avec tôle en Laiton DeLabré strié G7, Acier inox DeLabré strié 7022 F12 ou Acier inox DeLabré B E5. Bord à 45° et poignée en massif d'essence.

DESSUS SUPÉRIEUR: panneau de latté plaqué en Fossil oak ou en chêne fumé, fini avec peinture transparente à l'eau ou à base de solvant. Ou panneau interne en aluminium structurel revêtu avec tôle en Laiton DeLabré strié G7, Acier inox DeLabré strié 7022 F12 ou Acier inox DeLabré B E5. Ou marbre Grey Stone, blanc Carrara, Calacatta Oro, Emperador Dark, Gris Carnique fini à la main et traité avec des produits hydrofuges ou fini avec polyester mat. Ou composite MDI.

EMBASE: acier peint à poudre noir mat et pied en acier bruni. Patin réglable en thermoplastique.

PIEDS: acier bruni. Patin réglable en thermoplastique.

+info:
<http://www.depadova.com/materials.pdf>

Exemples de composition

M75

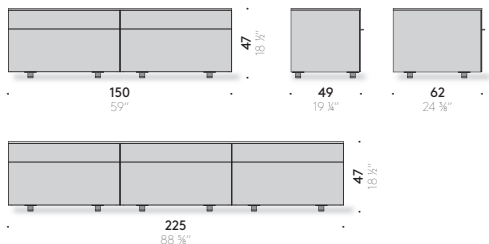

M75

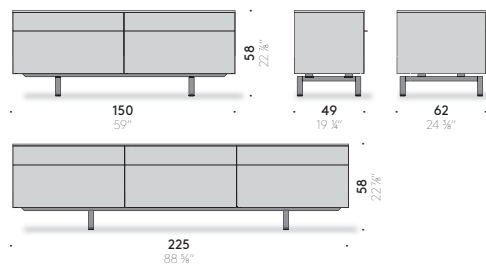

M90

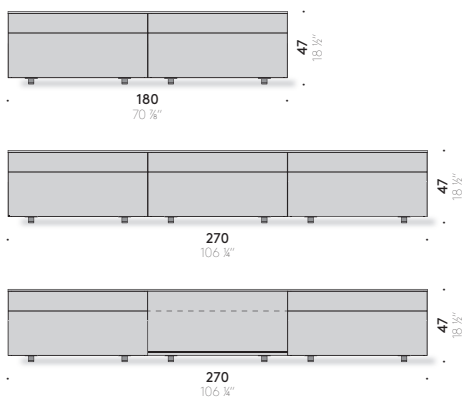

M90

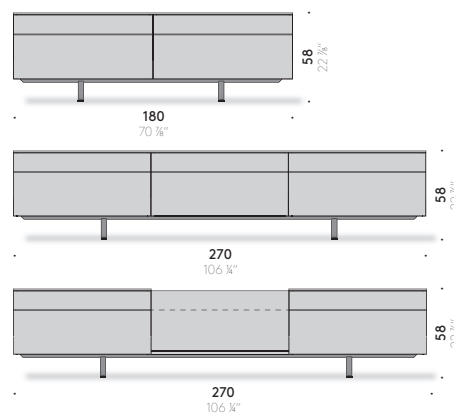

M120

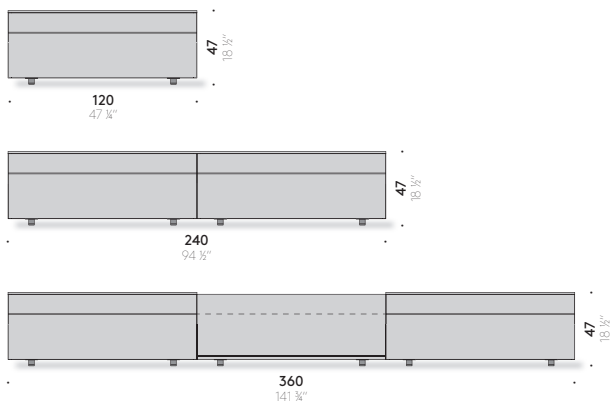

M120

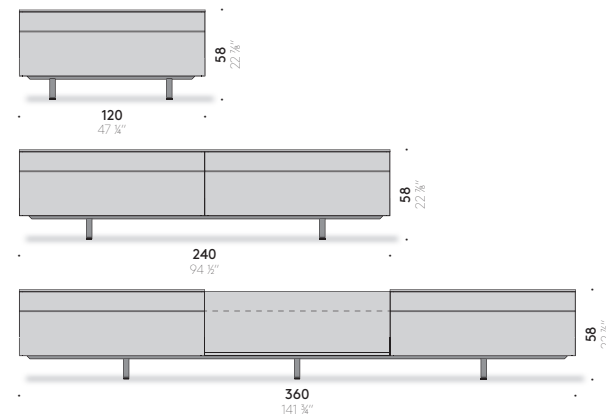

SC16 2016



Schrankelement

Materialien

KORPUS: Tischlerplatten, furniert in Fossil oak oder Räuchereiche, endbehandelt mit transparentem Lack auf Wasser- oder Lösemittelbasis. Ecke 45° aus Massivholz Fossil oak oder Räuchereiche.

SCHUBLADEN: Tischlerplatte, furniert in Fossil oak oder Räuchereiche, endbehandelt mit transparentem Lack auf Wasser- oder Lösemittelbasis. Montiert auf Führungsschienen mit Einzugsdämpfer.

SCHUBLADENFRONTEN: Tischlerplatten, furniert in Fossil oak oder Räuchereiche, endbehandelt mit transparentem Lack auf Wasser- oder Lösemittelbasis. Oder hergestellt aus Blech in Messing gestreift DeLabré G7, Edelstahl gestreift DeLabré 7022 F12 oder Edelstahl DeLabré B E5. Ecke 45° und Griffe aus Massivholz.

OBERPLATTE: Tischlerplatte, furniert in Fossil Oak oder Räuchereiche, endbehandelt mit transparentem Lack auf Wasser- oder Lösemittelbasis. Oder Innenpaneel in Strukturaluminium verkleidet mit Blech in Messing gestreift DeLabré G7, Edelstahl gestreift DeLabré 7022 F12 oder Edelstahl DeLabré B E5. Oder Marmor Grey Stone , weißer Carrara-Marmor, Marmor Calacatta Oro, Emperador Dark oder Grau Carnico von Hand endbehandelt, und mit wasserabweisenden Produkten behandelt oder mit mattem Polyester beschichtet. Oder Verbundmaterial MDI.

UNTERGESTELL: Pulverlackiertes Stahlgestell mattschwarz und Fuß aus brüniertem Stahl. Verstellbarer Thermoplast-Gleitfuß.

FÜSSE: aus brüniertem Stahl. Verstellbarer Thermoplast-Gleitfuß.

+info:
<http://www.depadova.com/materials.pdf>

Kompositionsbeispiele

M75

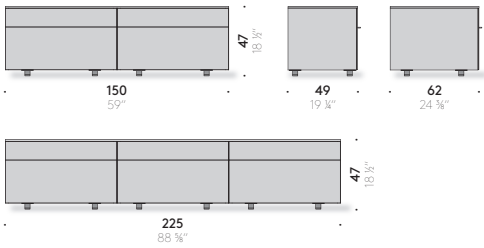

M75

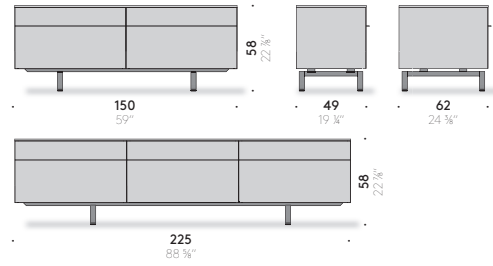

M90

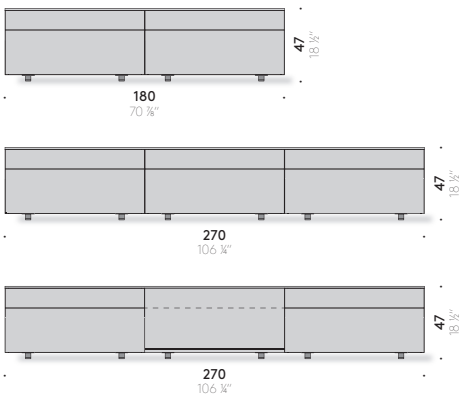

M90

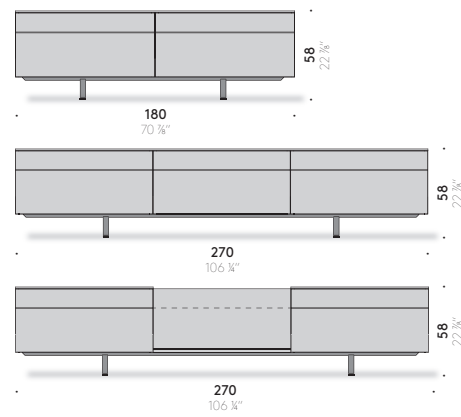

M120

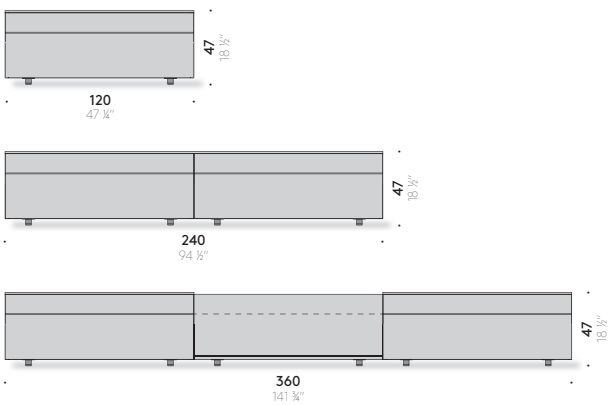

M120

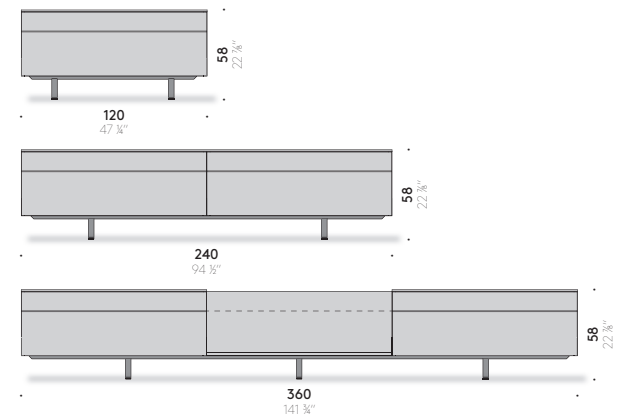

SC16 2016



Mueble contenedor

Materiales

ESTRUCTURA MUEBLE CONTENEDOR: paneles de madera alistonada chapados en Fossil oak o roble ahumado, acabados con pintura transparente al agua o al disolvente. Borde en 45° de madera maciza de Fossil oak o roble ahumado.

CAJONES: madera alistonada de Fossil oak o roble ahumado, acabados con barniz transparente al agua o al disolvente, montados sobre guías con mecanismo de amortiguación.

FRENTES CAJONES: madera alistonada chapada con Fossil oak o roble ahumado, acabados con pintura transparente al agua o al disolvente. O con chapa de Latón DeLabré estriado G7, Acero inoxidable DeLabré estriado 7022 F12 o Acero inoxidable DeLabré B E5. Borde en 45° y tirador de madera maciza.

TABLERO SUPERIOR: madera alistonada chapada con Fossil oak o roble ahumado, acabados con pintura transparente al agua o al disolvente. O panel interior de aluminio estructural recubierto con chapa de latón DeLabré estriado G7, Acero inoxidable DeLabré estriado 7022 F12 o Acero inoxidable DeLabré B E5. O mármol Grey Stone, blanco Carrara, Calacatta Oro, Emperador Dark, Gris de Carnia acabado a mano y tratado con productos repelentes al agua o acabado con poliéster mate. O compuesto MDI.

BASE: acero pintado en polvo negro mate y pie de acero bruñido. Bajo-pie ajustable de termoplástico.

PIES: acero bruñido. Bajo-pie ajustable de termoplástico.

+info:
<http://www.depadova.com/materials.pdf>

Ejemplos de composición

M75

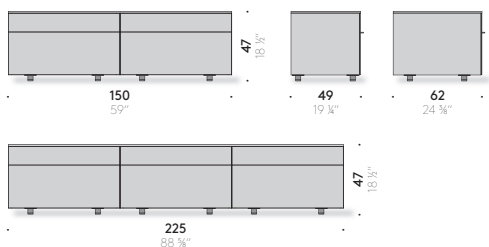

M75

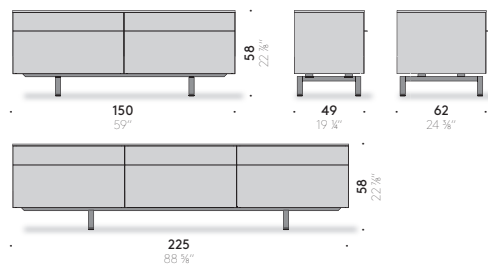

M90

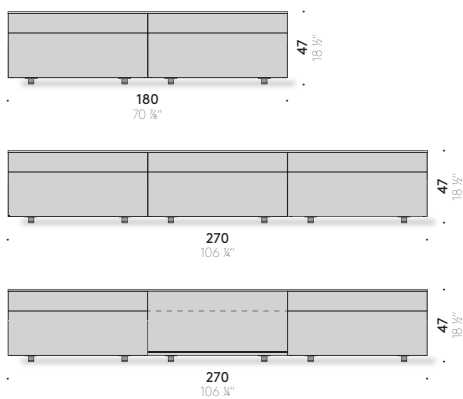

M90

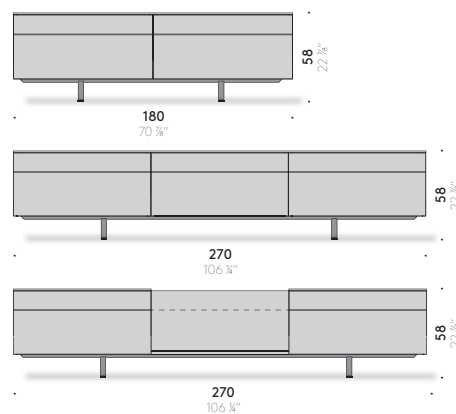

M120

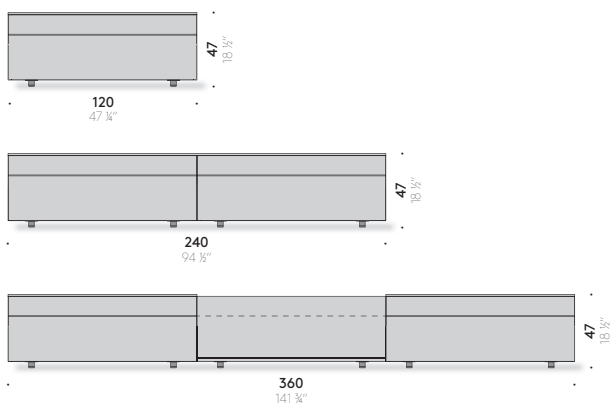

M120

